

# Cassina

## 550 BEAM SOFA SYSTEM

Year of production **2016**

This seating system comprises three sofas, which can also be used individually, and modular padded elements: two or three-seater end units with left- or right-hand armrest, two-seater center units, corner units and left- or right-hand chaise longues, ottoman and center or end low tables. Each element rests on a "beam" base: geometric, formal, with a strong aesthetic impact, the base is the functional core of the system. Indeed, it enables various configurations to be created, arranging the padded elements together or alternating the seating, tables and ottoman in interesting compositions. This contemporary take focuses on practicality and comfort together with attention to detail, to enhance its aesthetic characteristics: soft, cosy yet not excessively huge cushions, the high back, stitching detail along the edges, the sideways protrusion of the overlapping back and the armrest and the two possible positions of the armrest for quality relaxation. Structure: steel tube. Padding: variable density CFC-free polyurethane foam. Base: black anodised aluminium. Feet: clear plastic. Removable upholstery in fabric or leather. Table finishes: American walnut, natural oak, blackstained oak, cement-stone.

Gallery

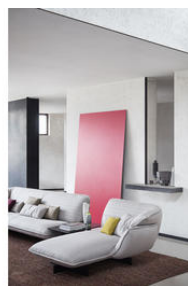
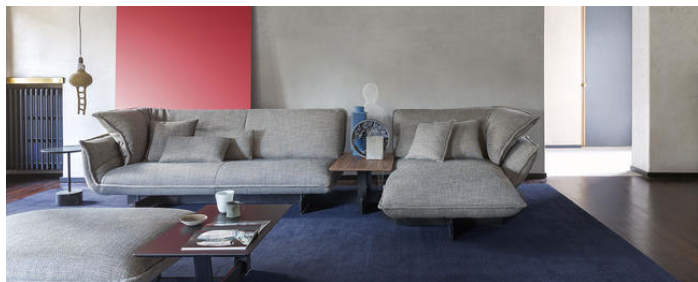

# Dimensions

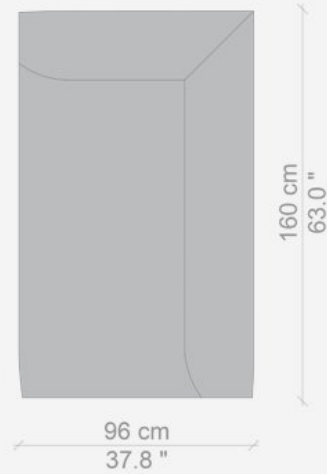
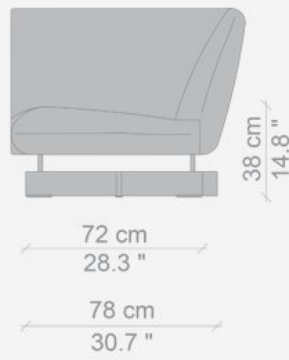
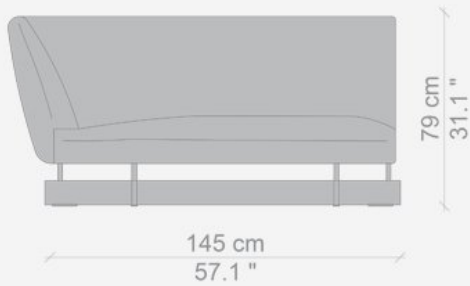
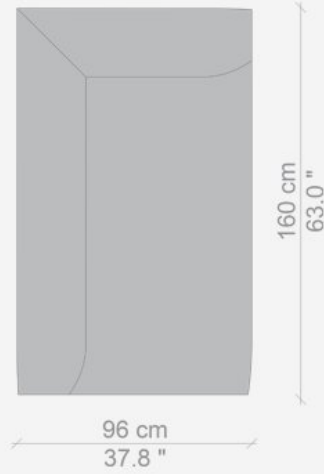
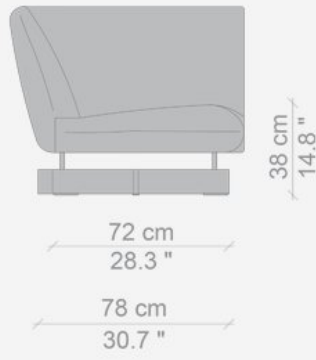
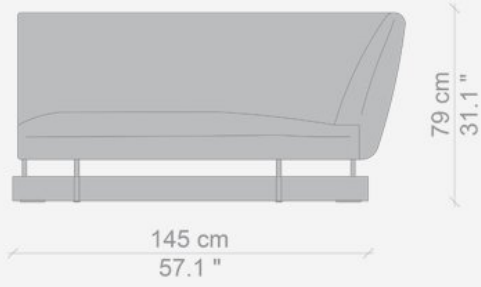

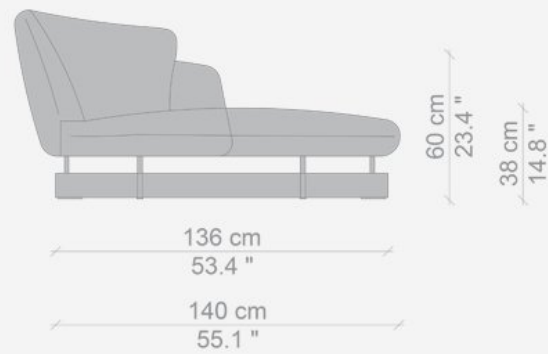
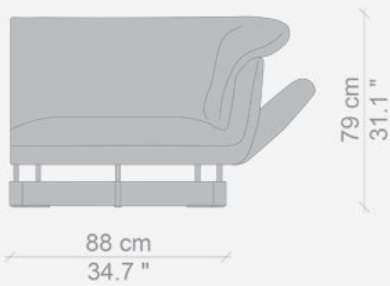
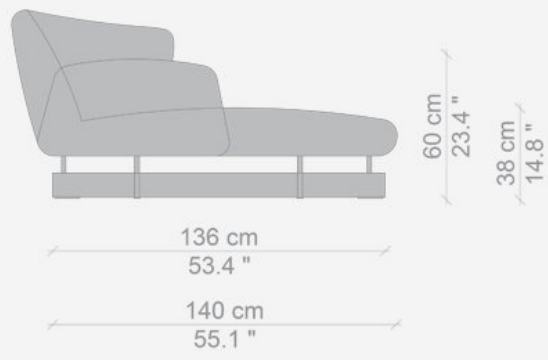
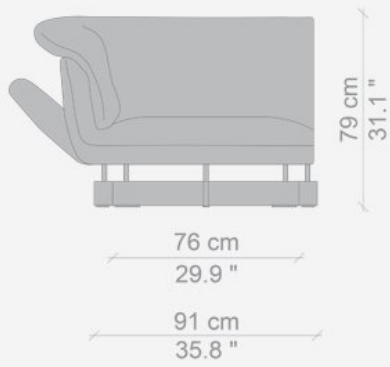



153 cm  
60.2 "

79 cm  
31.1 "



72 cm  
28.3 "

60 cm  
23.4 "

38 cm  
14.8 "

96 cm  
37.8 "

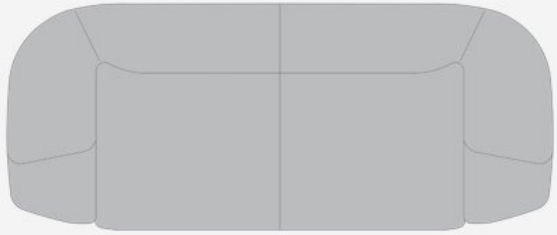

220 cm  
86.6 "

96 cm  
37.8 "



183 cm  
72.0 "

79 cm  
31.1 "



72 cm  
28.3 "

60 cm  
23.4 "

38 cm  
14.8 "

96 cm  
37.8 "

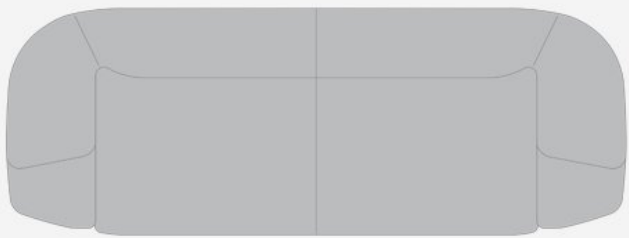

250 cm  
98.4 "

96 cm  
37.8 "

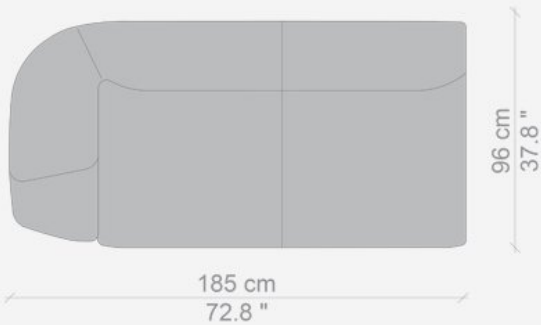
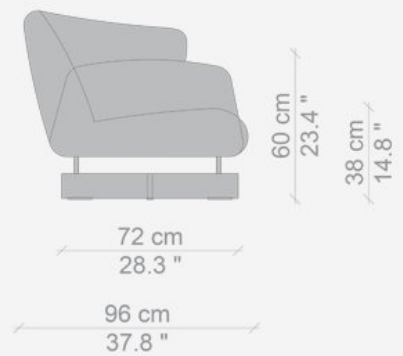
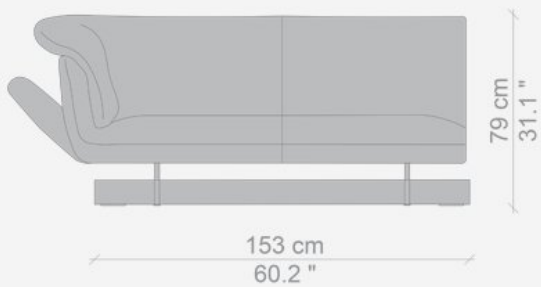
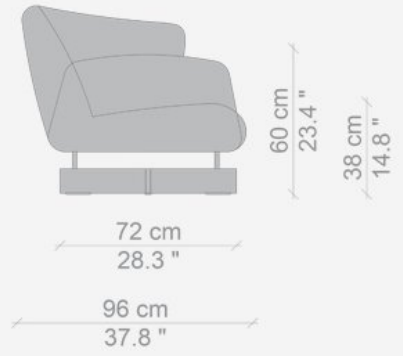

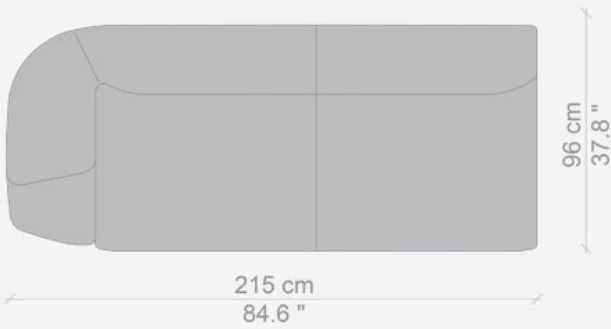
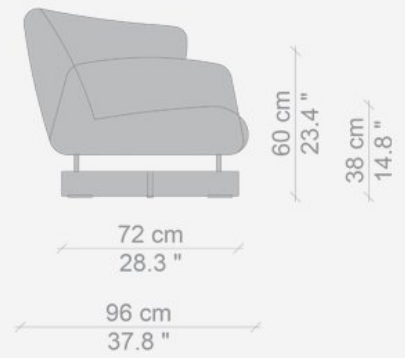
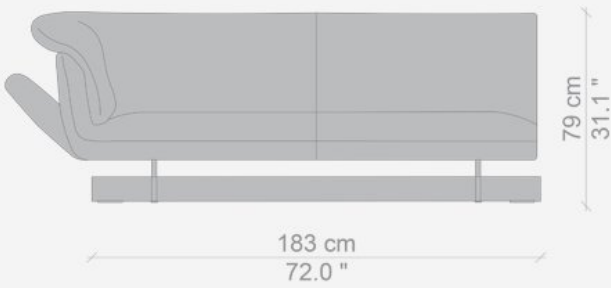
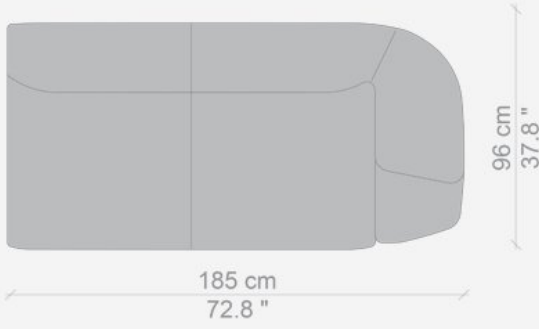
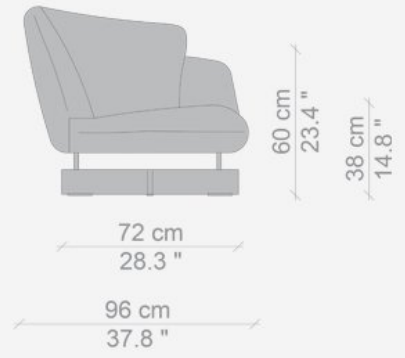
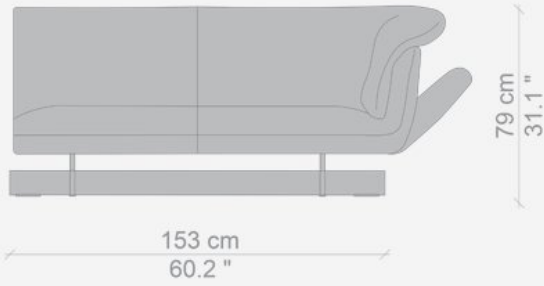

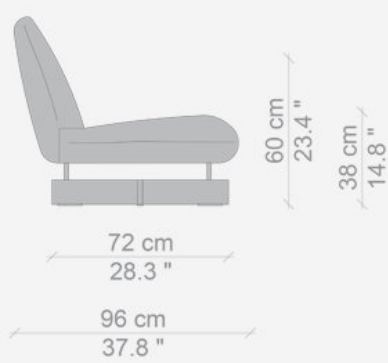
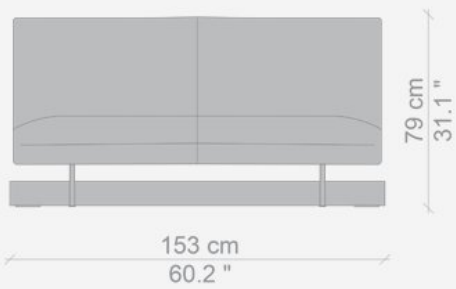
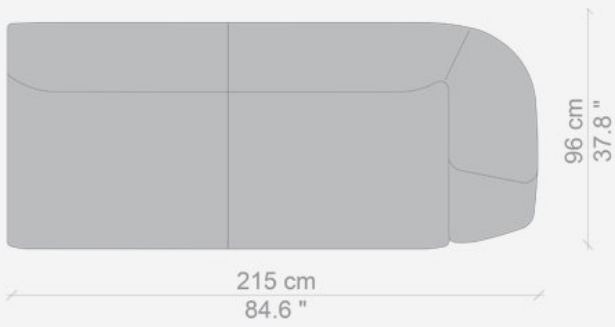
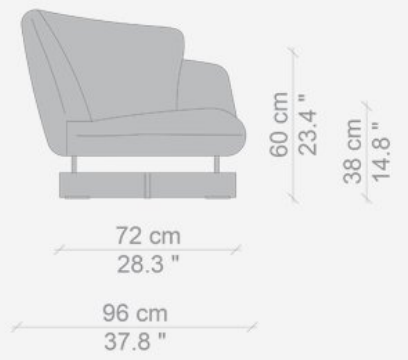
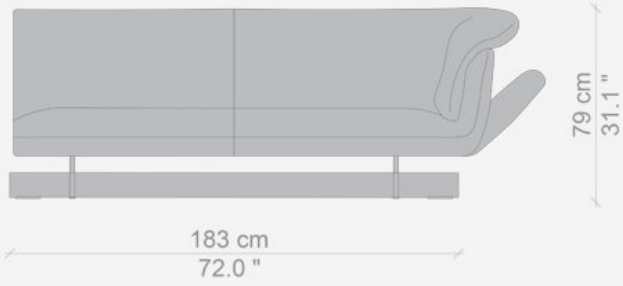



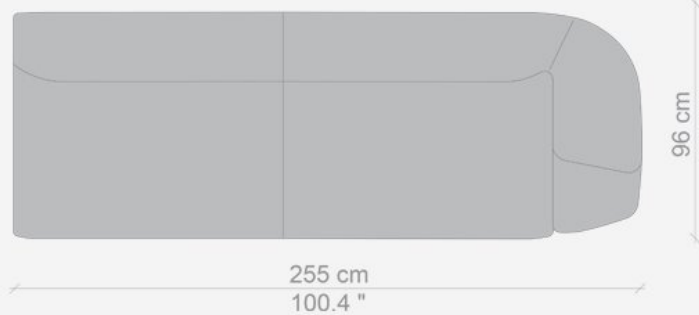
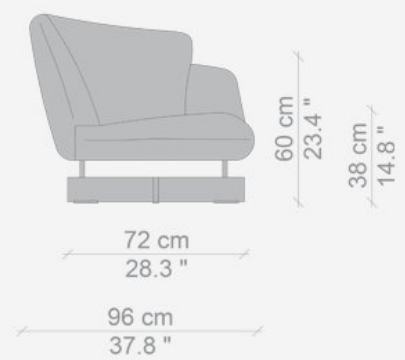
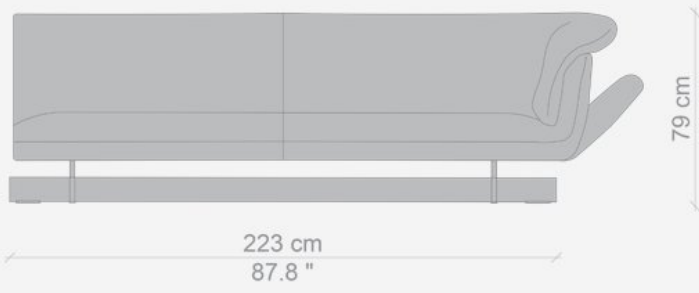
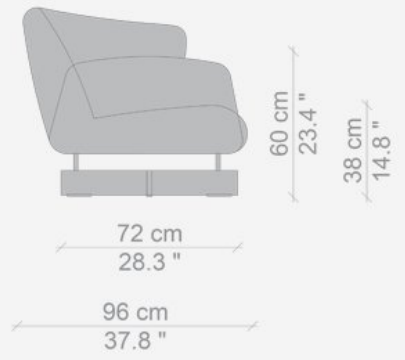
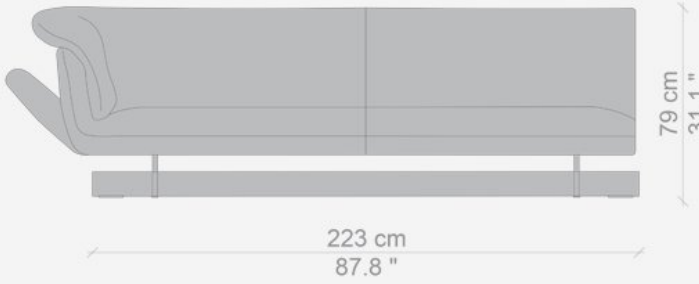





50 cm  
19.7 "



80 cm  
31.5 "

38 cm  
14.8 "



50 cm  
19.7 "



80 cm  
31.5 "

38 cm  
14.8 "



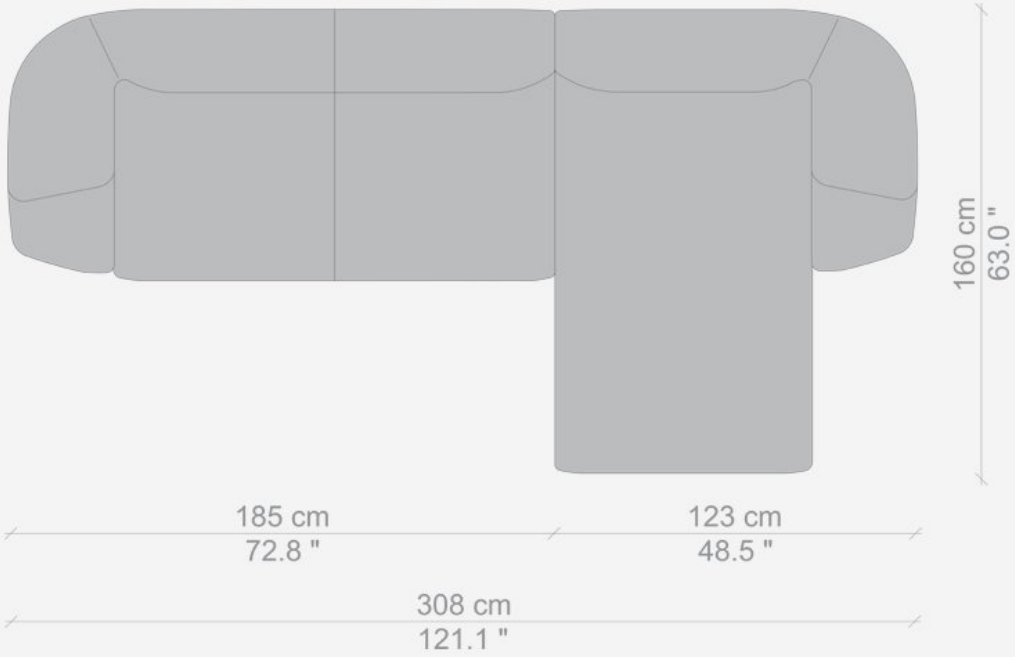
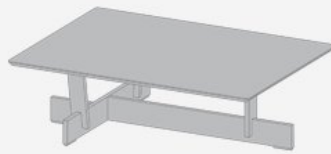
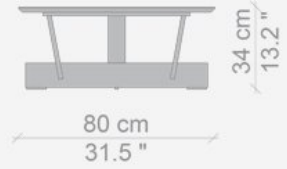

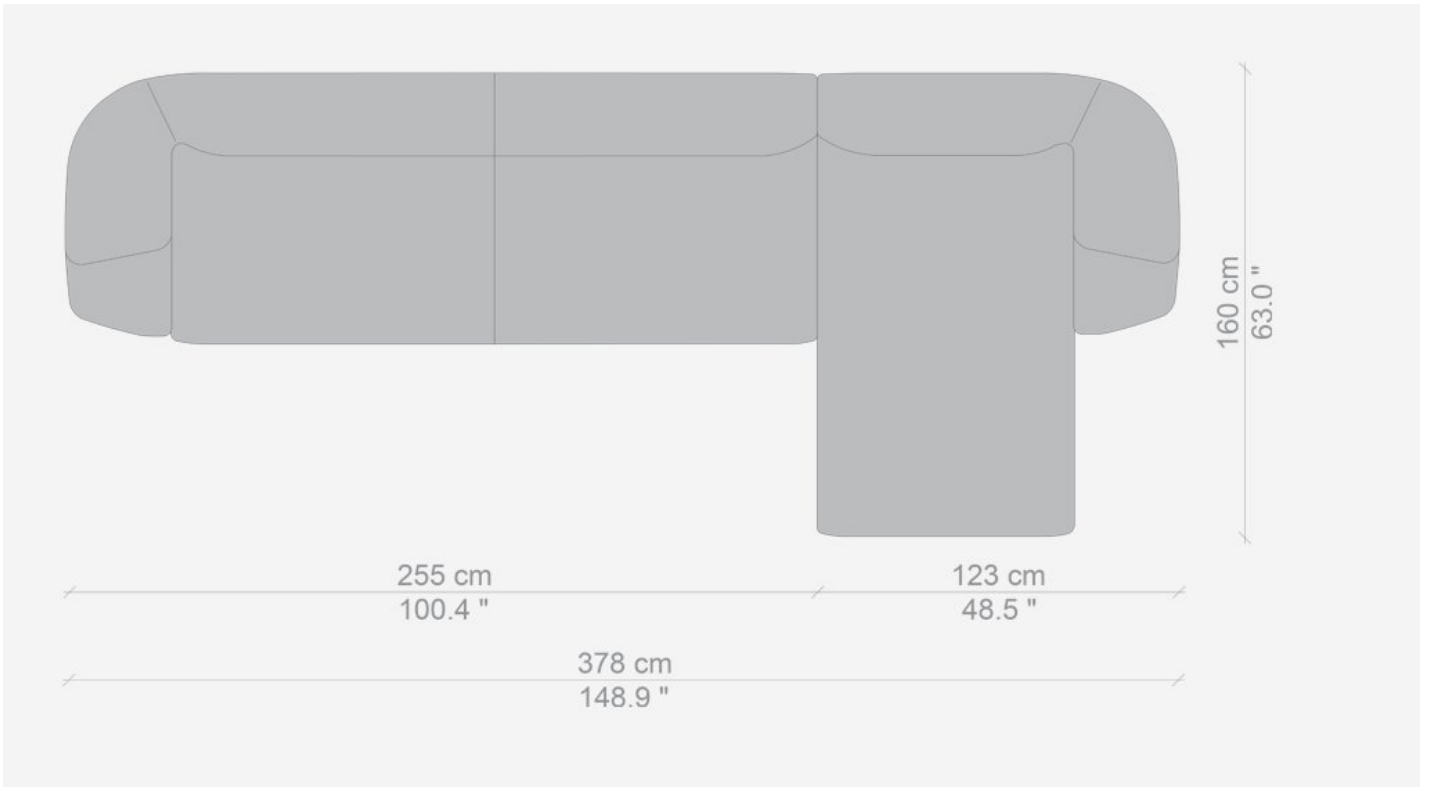
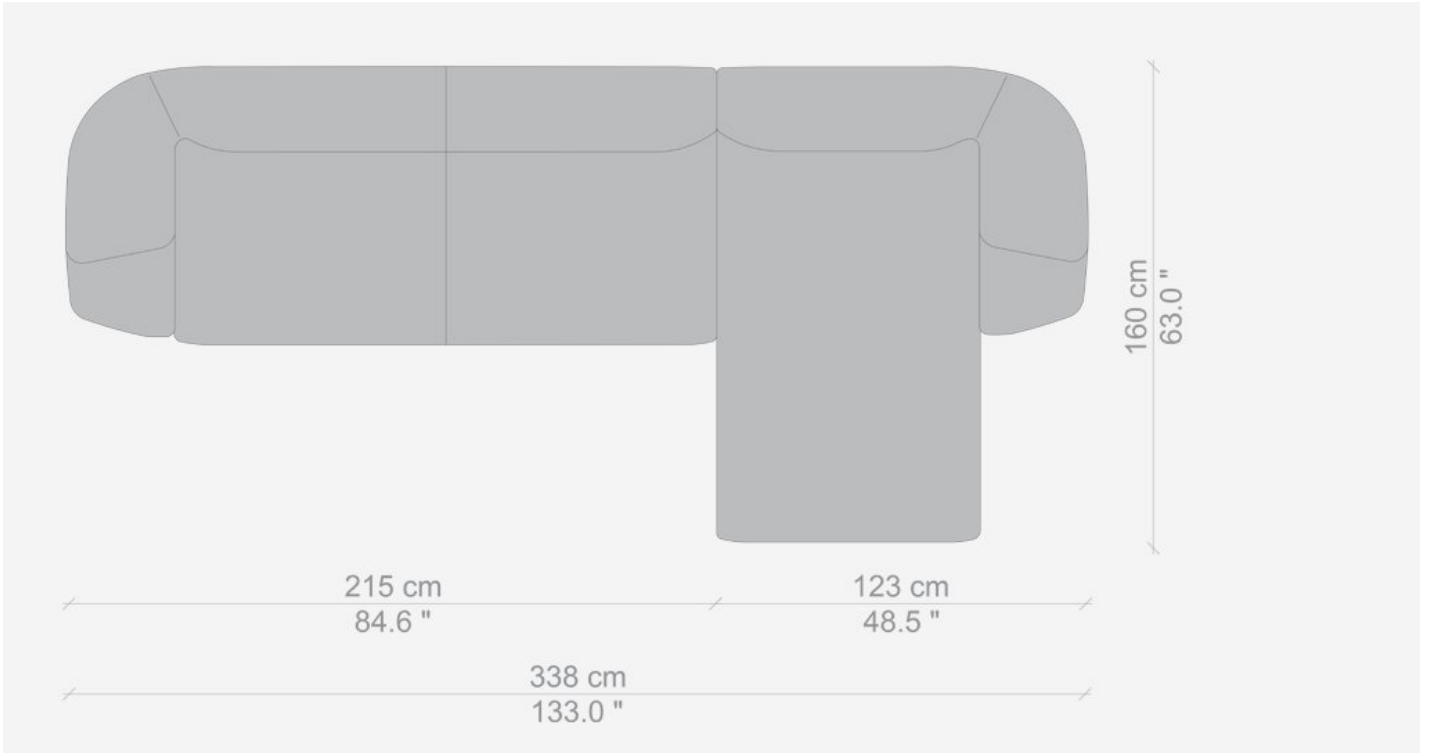

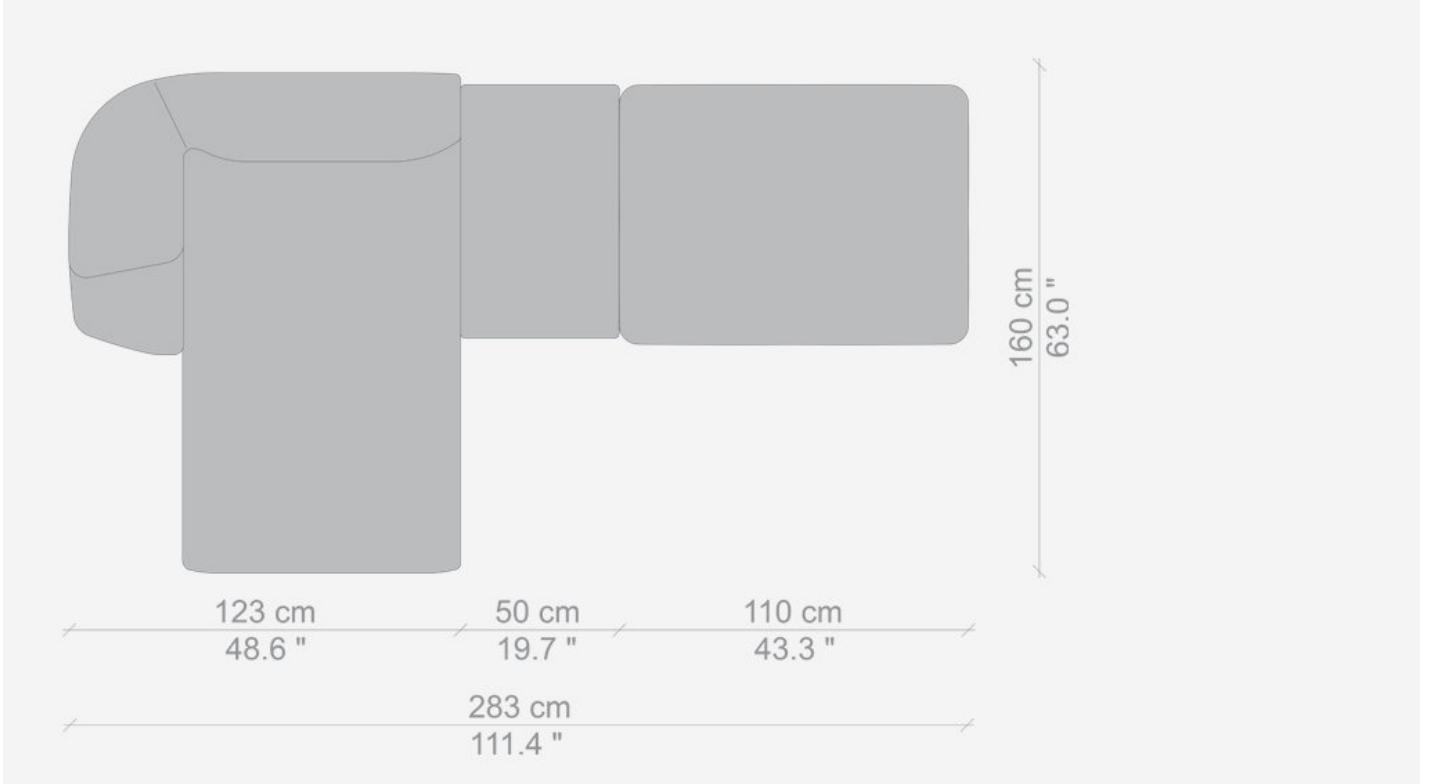

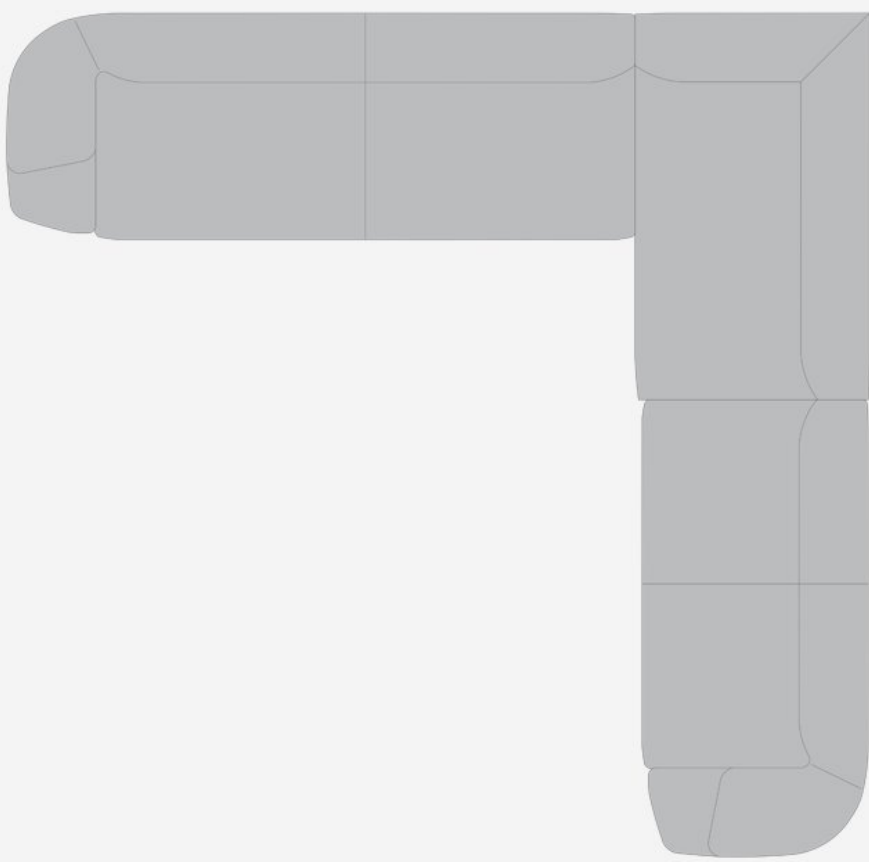

160 cm  
63.0 "

345 cm  
135.8 "

185 cm  
72.8 "

255 cm  
100.4 "

96 cm  
37.8 "

351 cm  
138.2 "

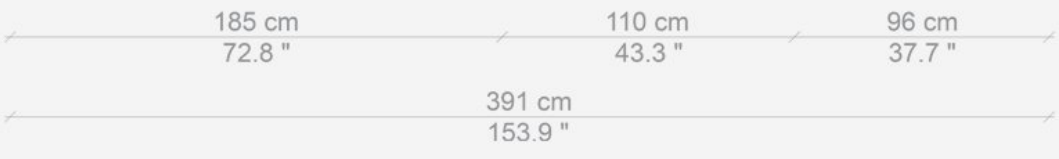
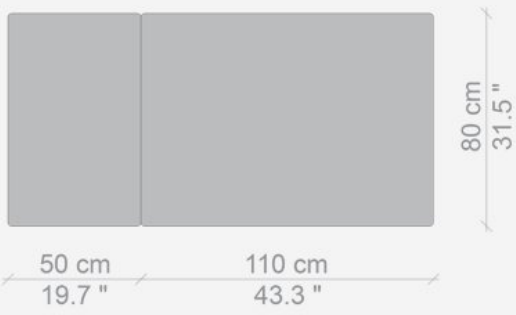
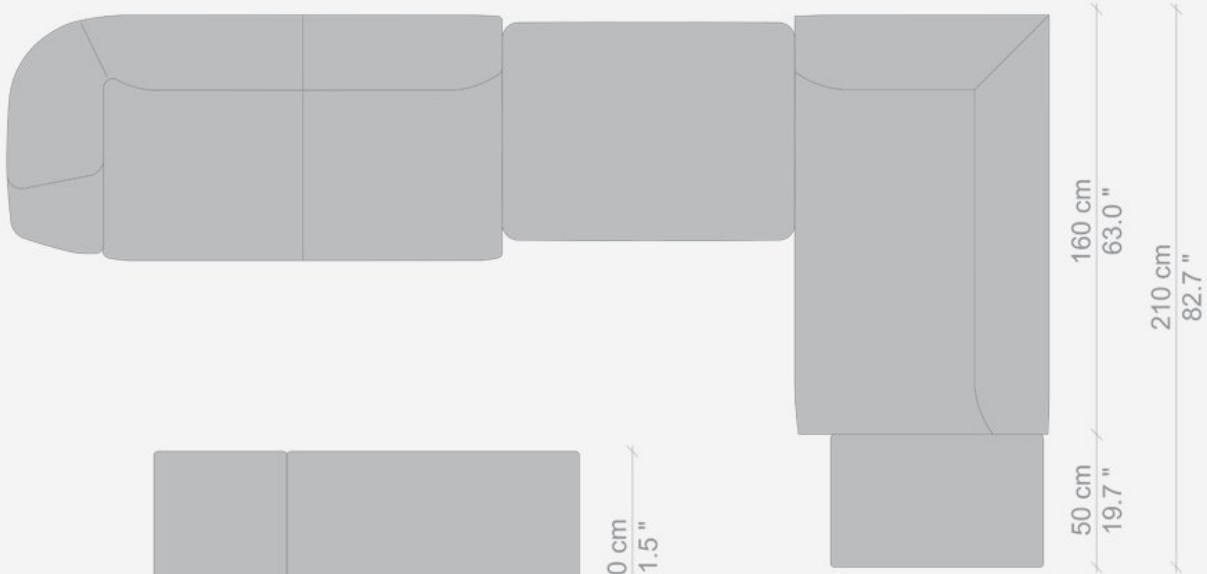



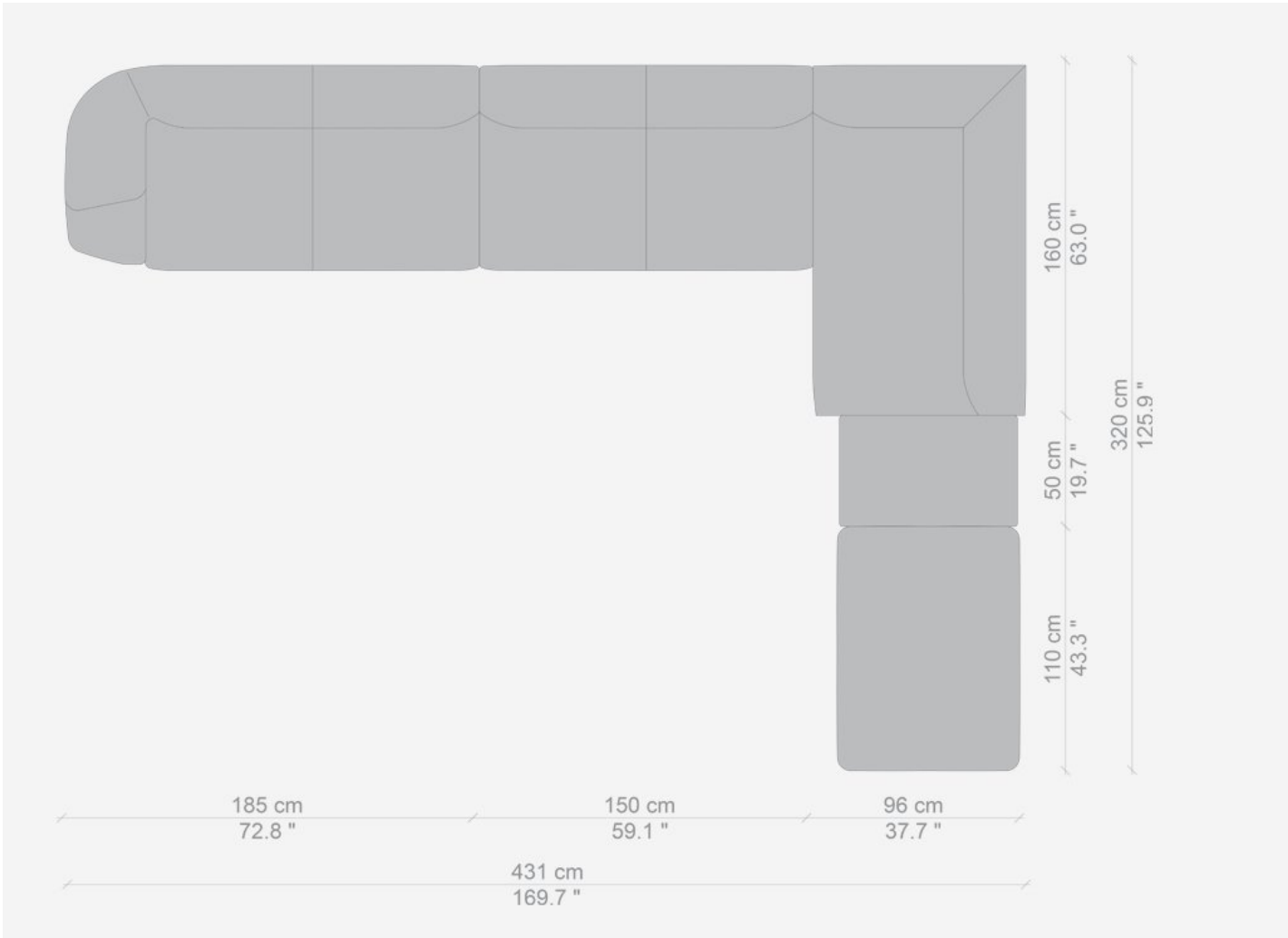

## Authenticity

All the models in the Cassina collection, by merit of their artistic content and particular creative character, are protected by copyright, a legal institution that is universally recognised and safeguarded; legal protection is assured for the whole life-span of the author and for 70 years after his/her death (or the death of the last surviving co-author).

## Designer



**Patricia Urquiola**

*Patricia Urquiola was born in Oviedo (Spain) in 1961. Lives and works in Milan. She attended the University of Architecture at Madrid Polytechnic and Milan Polytechnic, where she graduated in 1989 with Achille Castiglioni. Assistant lecturer to Achille Castiglioni and Eugenio Bettinelli in Milan and Paris, responsible for the new product development office of DePadova, working with Vico Magistretti, head of Lissoni Associati's design group. In 2001 she opened her own studio working on product design, architecture, and installations. Amongst her last projects of architecture: The museum of Jewel in Vicenza, Mandarin Oriental Hotel in Barcelona, das Stue Hotel in Berlin and the Spa of Four Seasons Hotel in Milan; showroom and installations for Gianvito Rossi, BMW, Cassina, Missoni, Moroso, Molteni, Officine Panerai, H&M, Santoni and the general concept of Pitti Immagine Firenze. She realize design products for the most important Italian and international companies, such as : Agape, Alessi, Axor-Hansgrohe, B&B Italia, Baccarat, Boffi, Budri, De Padova, Driade, Ferragamo, Flos, Gan, Georg Jensen, Glas Italia, Haworth, Kartell, Kettal, Kvadrat, Listone Giordano, Louis Vuitton, Molteni, Moroso, Mutina, Rosenthal and Verywood. Some of her products are exposed in various Museums and collections, such as MoMA in New York, Les arts decoratifs in Paris, the Museum of Design in Zurich, Vitra Design Museum in Basel, Victorian&Albert Museum in London, Stedelijk in Amsterdam and Triennale Museum in Milan. She has won several international prizes and awards. Amongst others the Medalla de Oro al Mérito en las Bellas Artes (Gold Medal of fine arts) awarded by the Spanish Government; Order of Isabella the Catholic, awarded by His Majesty The King of Spain Juan Carlos I; "Designer of the decade" for two German magazines, Home and Häuser, "Designer of the Year" for Wallpaper, Ad Spain, Elle Decor International and Architektur und Wohnen Magazine. She is Ambassador of Expo Milano 2015. September 2015 Patricia Urquiola nominated Art Director of Cassina.*