

Cassina

114 NUVOLA ROSSA

Catalogue I Contemporanei

Year of production 1977

Simplicity and essentialism are the main characteristics of this bookcase designed by Vico Magistretti in 1977 and produced in the same year. A foldable bookcase which, according to Magistretti's modus operandi, sprang from an analysis and reinterpretation a product type and the sum of its parts, the sides and shelves.

From here, the object was reduced to the diagonal brace elements, used also as a support for the shelves, thus eliminating the sides.

Nuvola Rossa is made in natural or black and white painted beech and, more recently, in a red painted version. There is also a Canaletto walnut version.

Gallery

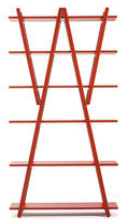
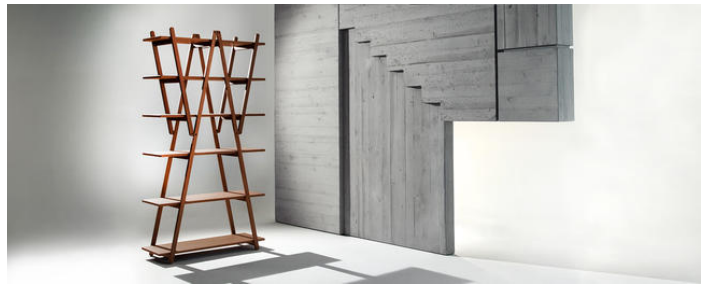



Dimensions

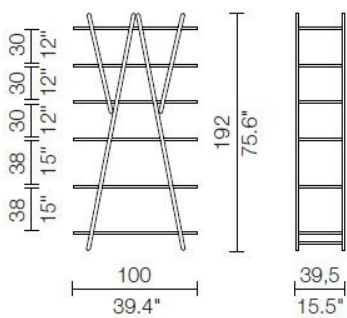

Authenticity

All the models in the Cassina collection, by merit of their artistic content and particular creative character, are protected by copyright, a legal institution that is universally recognised and safeguarded; legal protection is assured for the whole life-span of the author and for 70 years after his/her death (or the death of the last surviving co-author).

Designer

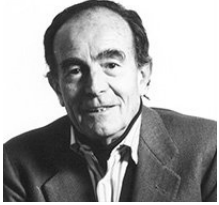

Vico Magistretti

In 1920 Magistretti was born in Milan, the city in which he graduated in architecture in 1945, and where his professional career has spun its story ever since, chiefly in the fields of architecture, town planning and industrial design. The first recognition of his work came in 1948, when he won the Gran Premio at the 8th Triennale. After that came almost forty years of activity with other prizes and awards in recognition of Magistretti's work in various sectors in different countries.

Giving lessons and lectures in various faculties of architecture and schools of design in Italy and abroad, from Milan to New York, from Paris to London, a city to which he is particularly devoted, he has been an "Honorary Fellow" of the Royal College of Art since 1983.

Furniture, lamps and other objects that he designed may be found all over the world and the most important design museums have given exhibitions in his honour and kept examples of his work in their permanent collections.

Magistretti's research has been continuous - into design, the culture of the project and innovative experimentation with materials and space solutions, not to mention shapes and functions far from the rigours of fashion that they have passed through during the years. He started designing for Cassina in 1960, and from that date on his signature is to be found on very many products. We recall in particular the Maralunga sofa of 1973 and the Nuvola Rossa (1977) bookcase, which are still indisputable international best-sellers and have provoked hordes of imitations which have not been able to echo even faintly the success of the originals.

<http://www.vicomagistretti.it>