

"I wanted to design an armchair for relaxation, in keeping with classic traditions but at the same time mixing in some modern influences," says French designer Patrick Norguet, famous on the international scene for his "french touch".

And so the P22 armchair arose, a balanced combination of timeless design and comfort, an inviting armchair that stands out also for its modern appearance.

A matching footrest, which also acts as a pouf, makes it even easier to stretch out and relax.

The armchair is available in a version with or without headrest, in a wide range of removable upholstery also in different combinations of fabric and leather for the inner and outer parts according to specific patterns.

## Gallery





## Dimensions

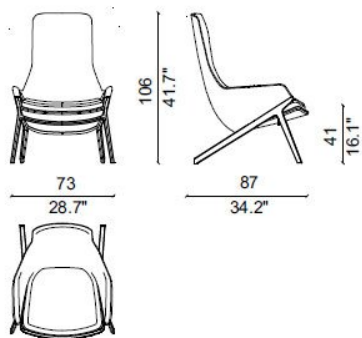
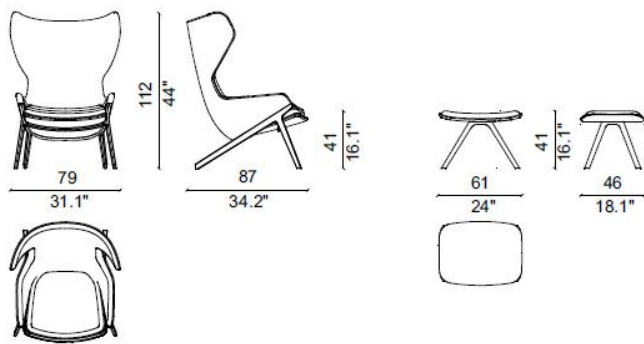

## Authenticity

All the models in the Cassina collection, by merit of their artistic content and particular creative character, are protected by copyright, a legal institution that is universally recognised and safeguarded; legal protection is assured for the whole life-span of the author and for 70 years after his/her death (or the death of the last surviving co-author).

## Designer



**Patrick Norguet**

French designer Patrick Norguet, close to fashion world through his collaboration with Louis Vuitton, Lanvin, Guerlain and Christian Dior, completes his personal formation at the EDSI where he built up a unique approach based on eclecticism and a thorough knowledge of materials and manufacturing processes. In 2000 he opened his personal design office; nowadays, he is involved in industrial and interior design, dedicating himself to create also exhibitions for Van Cleef and Renault. Awarded as "Designer of the Year" in 2005, Norguet belongs to that generation which is making known the "french touch" on the international stage; with his designs he perfectly interprets Cappellini's theory of the union between fashion and design, projecting items of great presence for both sectors, working for innovation but keeping the greatest simplicity. For brands such as Lancel, Cappellini, Poltrona Frau, Flaminia, Frighetto, Molteni&C, Gebruder Thonet Vienna, Maxdesign, Modus, Artifort and Bernhardt he loves to work on emotions and intuition, finding alternative slants on everyday objects and their specific settings.

Some of his works are part of the permanent collections of prestigious museums, such as the Museum of Modern Art in New York.